

## Linear Actuators RA 600, Industrial

Max. lifting force 1,000 to 6,000 N, stroke from 100 to 600 mm

Version with limit switches or stroke measuring system



### Application

Linear actuators RA 600 are used for electrically-operated adjustments and as actuating elements in applications with control-oriented demands in short-time service.

The actuators are suited for manifold industrial applications, indoors and outdoors.

### Principal use

- Machine tool building
- Food machines
- Building services engineering
- Conveyor and dosing technology
- Chemical industry
- Solar technology
- Renewable energy generation

### Fixing and installation

The linear actuators RA 600 have two fork eyes with  $\varnothing$  12 mm for the connection of user's constructions.

It has to be considered that the linear actuator has to be mounted protected against torsion. The pushing rod must be installed without any side loads.

The connecting construction has to be designed so that no forced conditions act on the pushing rod.

The electrical connection is made by coded plug-type connectors.

### Advantages

- High operating safety by self-locking spindle drive
- High static retention force
- Sturdy design by high-quality drive components
- Resistant against corrosion and disinfectants
- Press and splash water protection as per code class IP69K (optional)
- Reliable even with rough environmental conditions
- Compact design
- Mounting position: any
- Maintenance free
- Industrial design

### Description

Linear actuators RA 600 consist of a 24 V DC direct current drive, whose drive energy is transferred over a snail transmission and a spindle stroke transmission to the pushing rod.

The self-locking spindle lifting gear stops the actuator in case of voltage drop and maintains it safely in the reached position.

Features of the sturdy design are the generous dimensioning of the actuator and the solid design of the housing.

Alternative to code class IP66 also a press and splash water protection as per code class IP69K is available as an option.

Linear actuators RA 600 are protected against corrosion and function without any troubles also in rough operating and environmental conditions. Since they are maintenance-free, this is guaranteed permanently.

The version with limit switches is equipped with 2 sensors, that prevent an unintentional movement to the mechanical stroke ends and thus the overload of the mechanics.

The version with stroke measuring system allows the realisation of control-oriented applications and the operation of several linear actuators in synchronism.

The stroke ends are freely definable by means of the digital signal.

### Operation

Linear actuators RA 600 can optionally be operated by hand panel or foot switch and supply units of the accessory programme as per data sheet M 8.200 with touch control or by an external control with 24 V output.

The version with stroke measuring system delivers the user incremental signals of the stroke measuring system.

### Linear actuators RA 600 - 24 V DC

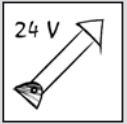

Part-no. I6-XX-XX-2-X-XS1A

### Technical characteristics

Max. push force:	1.000 - 6.000 N
Max. pull force:	80% of the push force
Stroke:	100 up to 600 mm
Max. duty cycle:	15%
Code class:	IP66 or IP69K

### Operational modes

- Touch control with supply unit and hand panel or foot switch (as per data sheet M 8.200)
- Control by external 24 V DC control

### Electrical interface

Plug-type connector 24 V DC

### Mechanical interface

2 fork eyes  $\varnothing$  12 mm  
( $\varnothing$  10 mm with accessory bearing sleeve)

### Accessories

- Bearing sleeve  $\varnothing$  12 /  $\varnothing$  10 mm
- Foot switch and hand panel as per data sheet M 8.200
- electrical supply units for 1, 2, 3 or 4 linear actuators as per data sheet M 8.200
- Plug

### Material

Cylinder body:	polyamide, black, glass fibre reinforced
Guiding tube:	aluminium, naturally anodised
Pushing rod:	stainless steel

### Important notes!

The linear actuators RA 600 are resistant against corrosion, detergents and disinfectants.

The admissible environmental temperature is  $-20^{\circ}$  up to  $+70^{\circ}$ C.



## Description

The version with limit switches has 2 integrated Hall-effect sensors, which automatically switch off the motor brake as soon as the upper or lower stroke end position is obtained.

This guarantees that the linear actuator does not mechanically push against the stop. At the plug-type connector of this version the pins 3 and 4 have to be connected to 24 VDC. By changing the polarity, switching over from retracting to extending is effected.

## Current consumption

As a function of the load the current consumption amounts linearly up to 6 A at nominal load. For a safe power supply, a supply current of at least 8 A is required.

## Static retention force

The static retention force can exceed the maximum lifting force by up to 25%.

## Technical characteristics

Force [N]	Velocity		Current consumption [Ampere]	Duty consumption cycle [max 1.5 min.]
	Idle running [mm/s]	loaded [mm/s]		
1000	37	29	6	max. 15 %
2000	21	18	5	max. 15 %
4000	11	7	5.5	max. 15 %
6000	8.5	5	7	max. 15 %

Stroke [mm]	L [mm]	L + stroke [mm]	Weight [kg]
100	310	410	3.2
150	360	510	3.6
200	410	610	4.0
300	510	810	4.5
400	650	1050	5.0
500	750	1250	5.7
600	850	1450	6.4

Note: Linear actuators RA 600 with a stroke of 400 mm or more are equipped with an enlarged guiding length.

## Code for part numbers

Part-no. I6-XX-XX-2-X-ES1A

### Maximum lifting force (Push force)

- 01 = 1,000 N
- 02 = 2,000 N
- 04 = 4,000 N
- 06 = 6,000 N

### Stroke

- 10 = 100 mm
- 15 = 150 mm
- 20 = 200 mm
- 30 = 300 mm
- 40 = 400 mm
- 50 = 500 mm
- 60 = 600 mm

### Code class

- B = IP66
- C = IP69K

## Circuit diagram and connection of plug-type connector for RA 600 with stroke end disconnection

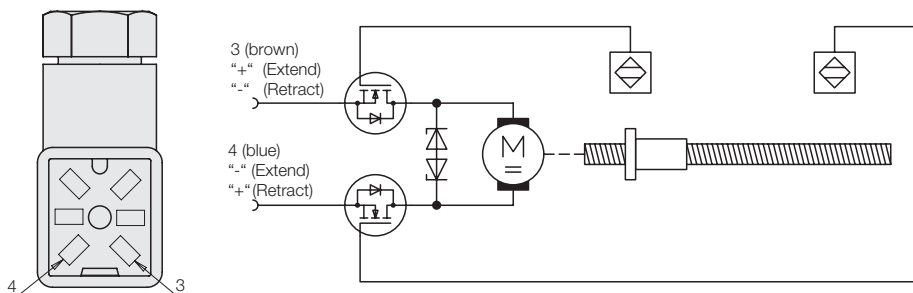

## Important notes!

Only RA 600 with incremental stroke measuring system can be operated in synchronism!

If the supply unit (see page 3) is not used, the user has to provide a current limitation of 10 A.

## Accessories

See page 3.

## Dimensions

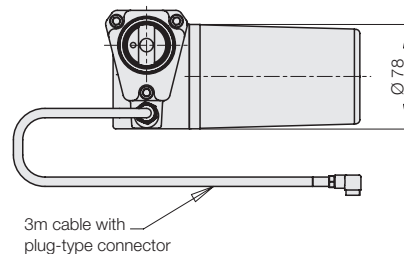
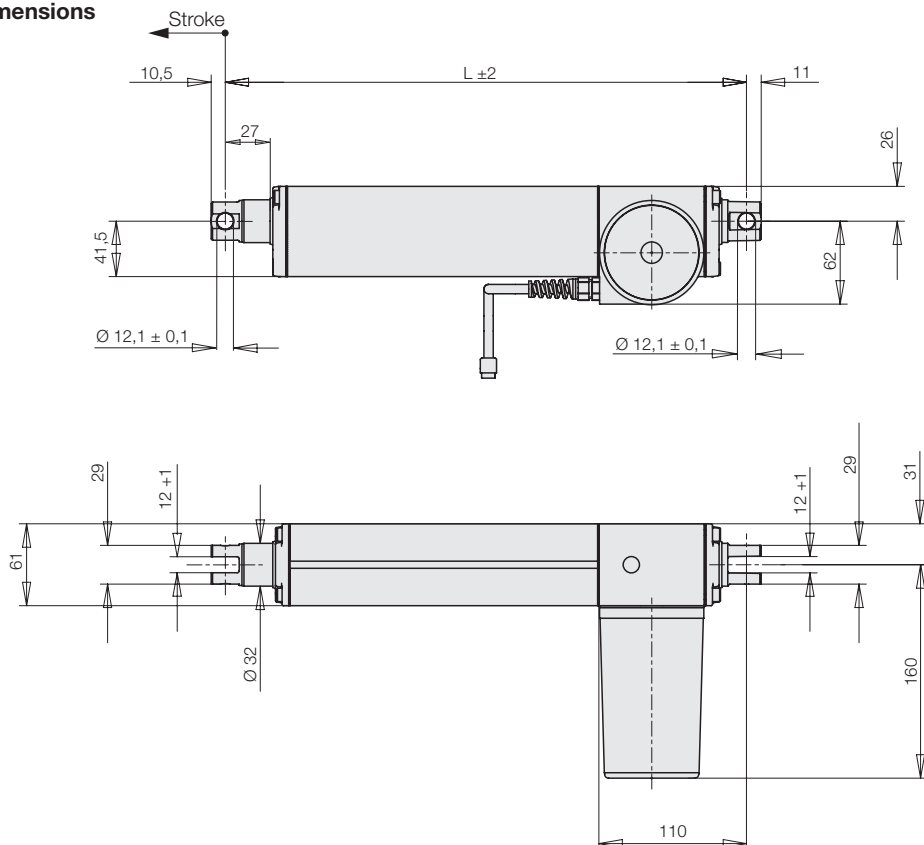

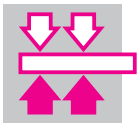

## Description

The stroke of linear actuators is transmitted by potential-free square wave signals, which are generated by the rotating spindle, to an external control.

An additional reference point, that initialises the stroke measuring system, is in the retracted stroke end position. This reference point can also be used to switch off the retracted stroke end position.

With the incremental stroke measuring system control-oriented applications and the compound of several linear actuators in synchronism can be realised.

Due to the incremental acquisition of the position, faults of linearity are excluded.

As accessory supply units with synchronization control for 2, 3 or 4 linear actuators are available.

Supply units as per page M 8.200 treat the actuators and the user's connecting construction with care due to a special control and thus contribute to the increase of the service life.

## Technical characteristics

See page 2.

### Resolution of the stroke measuring system

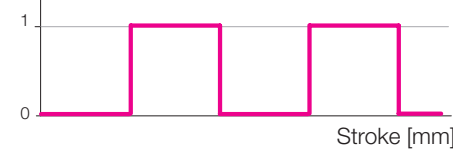

- 2 kN: 0.75 mm stroke = 1 edge to edge distance
- 4 kN: 0.5 mm stroke = 1 edge to edge distance
- 6 kN: 0.375 mm stroke = 1 edge to edge distance

## Code for part numbers

Part-no. I6-XX-XX-2-X-IS1A

### Maximum lifting force (Push force)

- 01 = 1,000 N
- 02 = 2,000 N
- 04 = 4,000 N
- 06 = 6,000 N

### Stroke

- 10 = 100 mm
- 15 = 150 mm
- 20 = 200 mm
- 30 = 300 mm
- 40 = 400 mm
- 50 = 500 mm
- 60 = 600 mm

### Code class

- B = IP66
- C = IP69K

## Circuit diagram and connection of plug-type connector for RA 600 with stroke measuring system

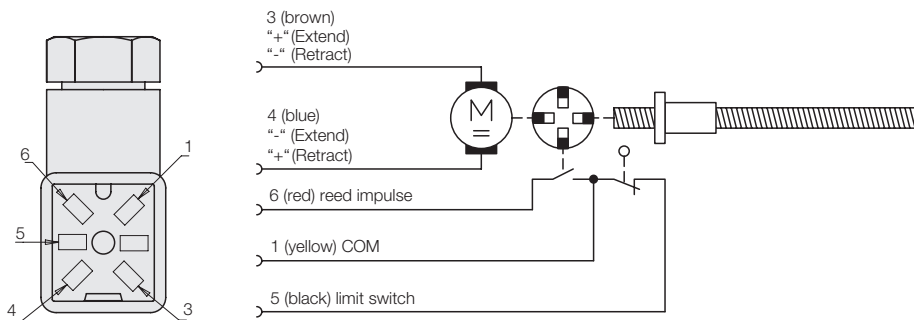

## Dimensions

See page 2.

## Important notes!

The stroke end positions must not be loaded mechanically. An approach in creep speed or switching off 3 mm before reaching the stroke end positions is required. For supply units with synchronization control this is met by the programmed soft stop function.

The positioning accuracy with touch control amounts to  $\pm 2$  mm, depending on the operator and the load.

Place task with higher demands on the positioning accuracy can be realised with special controls.

Therewith place accuracies within the size range of solution of the stroke measuring system can be realised.

In addition, there is the possibility to store temporarily up to 3 positions for reproducible approach.

## Accessories

- Bearing sleeve for fork eye  
DU bushing  $\text{Ø}12 / \text{Ø}10$   
**Part-no. 3301-936**

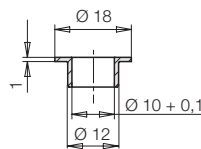

## Electrical accessories

See data sheet M 8.200

### ● Foot switch

for touch control up-down with connecting cable 1.5 m  
**Part-no. 3823-029**



### ● Hand panel

for touch control up-down with connecting cable 1.6 m  
**Part-no. 3823-025**



### ● Supply unit with control

for one linear actuator  
**Part-no. 3821-246**



### ● Supply unit with synchronization control

for 2 linear actuators  
**Part-no. 3821-400**  
for 3 linear actuators  
**Part-no. 3821-401**  
for 4 linear actuators  
**Part-no. 3821-402**



### ● Mains cable 230 VAC

with earthing type plug for supply units

Mains cable smooth, 3.0 m  
**Part-no. 3823-040**

### ● Plug

for user's control with 5 soldered strands and blade receptacles  
**Part-no. 3823-048**

