

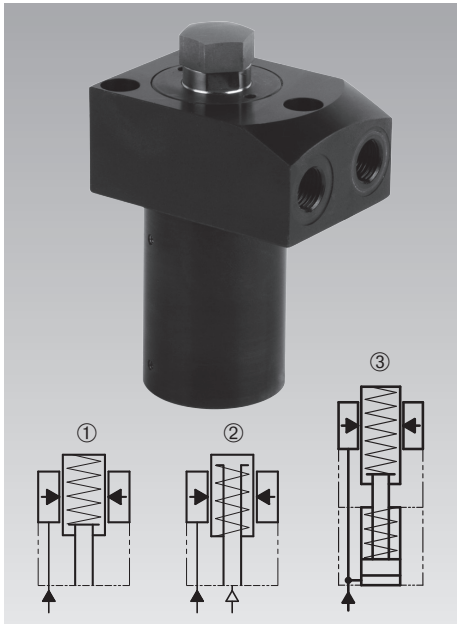

Work supports

Top flange type with metallic wiper edge, 3 sizes, 3 types of function, single acting, max. operating pressure 500 bar



Advantages

- Space-saving version
- 3 sizes
- 3 types of function
- Contact force by spring or pneumatically adjustable (195X321)
- Load force up to 100 kN
- Alternatively pipe thread or drilled channels
- Metallic wiper edge and FKM wiper
- Connection of positive air pressure protection is possible
- Support plunger and interior parts protected against corrosion

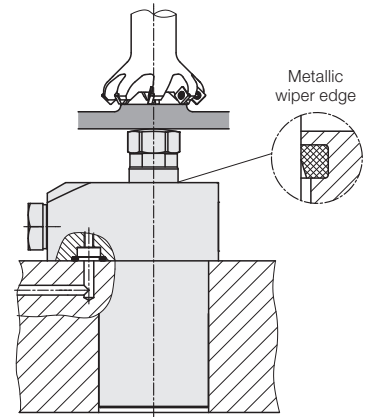

Types of function

1. Spring advanced

Page 2

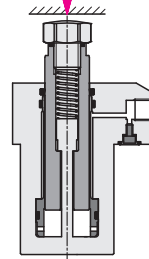

2. Air pressure advanced

Page 3

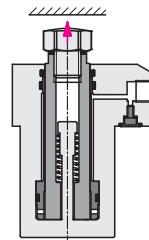

3. Hydraulic pressure and spring advanced

Page 4

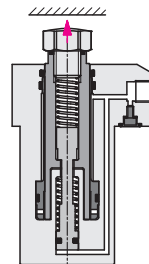

Combination with clamping elements

Page 5

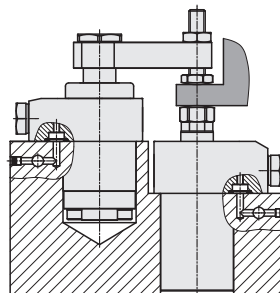

Application

Hydraulic work supports are used to provide a self-adjusting rest for the workpiece during the machining operations. They compensate the workpiece surface irregularities, also vibration and deflection under machining loads.

The top flange type allows for space-saving and direct installation into the fixture body. Oil supply is made through drilled channels or pipe thread.

Description

In the body of the work support a thin-walled locking bush is integrated, which locks cylindrically around the freely-movable support plunger when pressurising the element with hydraulic oil.

The elements are protected against penetration of swarf by a metallic wiper edge and sealed against liquids. The venting port allows also the connection of positive air pressure protection.

Important notes

Work supports are not suitable to compensate side loads.

If there is any danger of fluids being sucked into the filter, a vent hose has to be connected at the element or a venting port in the fixture body! Fluids must not be sucked in at the end of the vent connection!

It is absolutely necessary to follow the instructions for venting of the spring area see data sheet G 0.110.

The positive air pressure protection pressure > 0.2 bar must only be activated after hydraulic locking.

Operating conditions, tolerances and other data see data sheet A 0.100.

Admissible load force as a function of the operating pressure

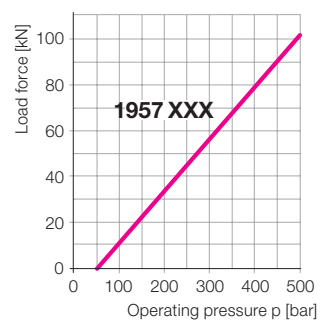
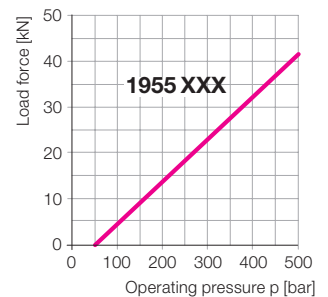
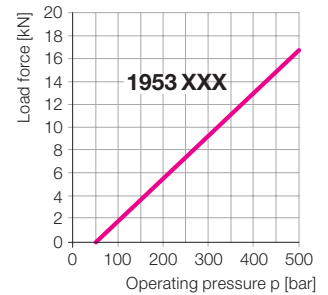

Important note

Machining forces can generate vibrations, whose amplitude exceeds an average value, and this can cause yielding of the support plunger. Remedy: increase the safety factor or the number of work supports.

Type of function: Spring advanced
off-position extended, contact by spring force

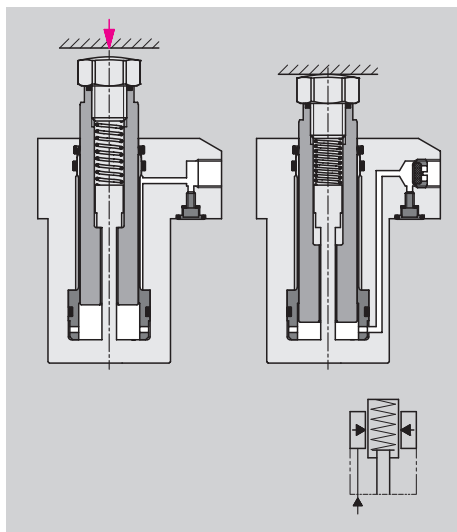

The support plunger is pushed back by the inserted workpiece, the spring force has to be overcome.

The support plunger will be locked by hydraulic pressure and can compensate forces in axis direction.

After unclamping the support plunger contacts still the workpiece with spring force, until the workpiece will be unloaded from the fixture.

Venting port

1. Dry machining

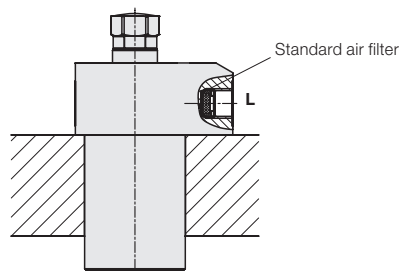

2. Wet machining

Pipe thread

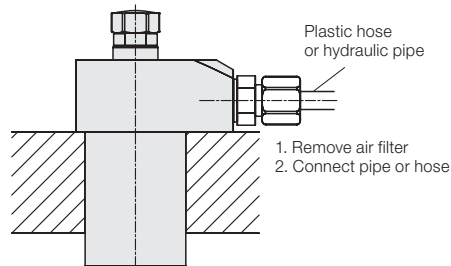

Manifold-mounting connection

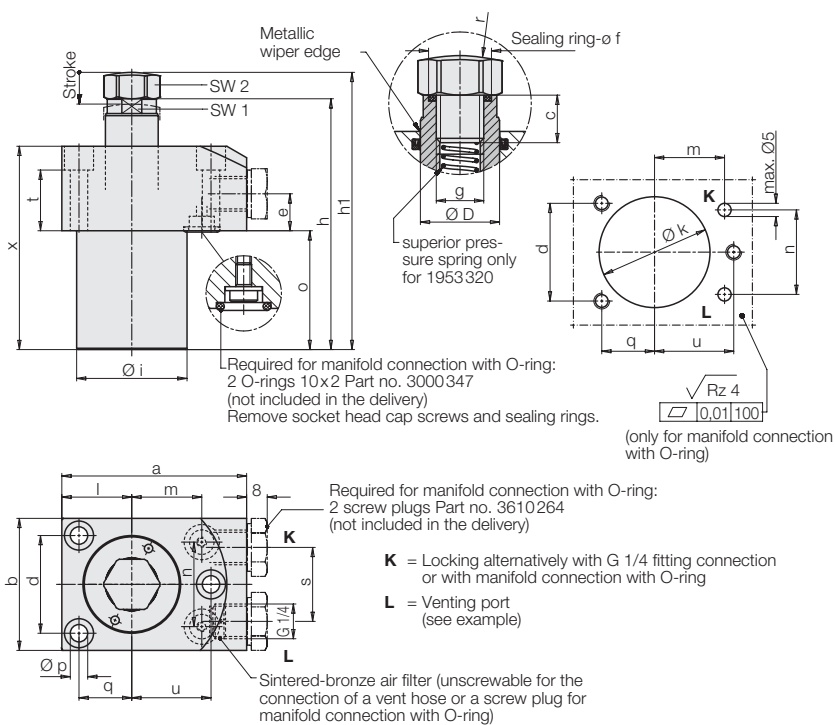
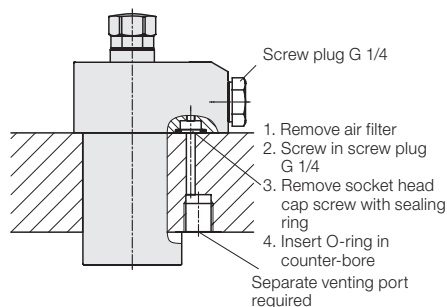

Support plunger Ø D	[mm]	20	32	50
Stroke	[mm]	12	16	20
Load force at 200/500 bar	[kN]	5,6/16,8	14/42	34/102
Plunger contact force min./max.	[N]	15/25	30/60	50/100
Elastic deformation at 500 bar	[µm/kN]	4,5	2,8	1,8
a	[mm]	70	85	125
b	[mm]	50	63	95
c	[mm]	12	12	20
d	[mm]	37	48	72
e	[mm]	14	18	15
Ø f	[mm]	15,9	15,9	19,6
g	[mm]	M12	M12	M16
h	[mm]	95	119	174
h1	[mm]	105	129	184
Ø i ± 0,1	[mm]	44,8	59,8	89,8
Ø k + 1	[mm]	45	60	90
l	[mm]	26,5	34,5	55
m	[mm]	26,5	31	45
n	[mm]	32	46	75
o	[mm]	45	59	106
Ø p	[mm]	6,6	8,5	14
q	[mm]	20	27	42
r	[mm]	45	45	60
s	[mm]	28	41	70
t	[mm]	23	29	26
u	[mm]	30	38	55
x	[mm]	77	99	146
SW 1	[mm]	17	27	41
SW 2	[mm]	19	19	24
Part no.		1953320	1955320	1957320
Spare O-ring 10 x 2 mm		3000347	3000347	3000347
Screw plug G 1/4		3610264	3610264	3610264
Spare sealing ring for contact bolt		3001731	3001731	3002018

Recommendation

Positive air pressure protection can be connected to the venting port. The pressure of the positive air pressure protection increases the contact force of the support plunger.

Type of function: Air pressure advanced
Extend and contact by air pressure

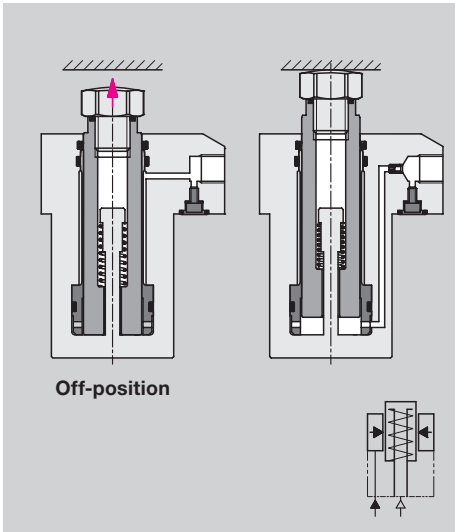

The support plunger contacts the workpiece by air pressure. The contact force is proportional to the air pressure less spring return force. The support plunger will be locked by hydraulic pressure and can compensate forces in axis direction.

For unclamping hydraulic and air pressure will be released and the support plunger retracts by spring force to its off-position.

Pneumatic port
Fitting connection

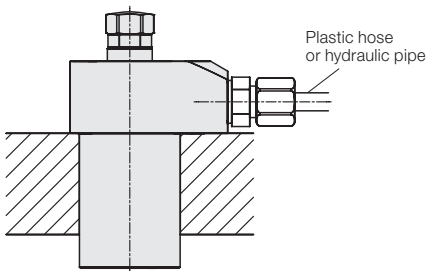

Manifold-mounting connection

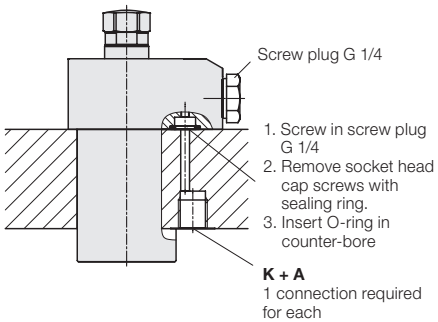

Recommendation

The pneumatic air for the extension of the support plunger can also be used as positive air pressure protection. For retraction the port must be depressurised.

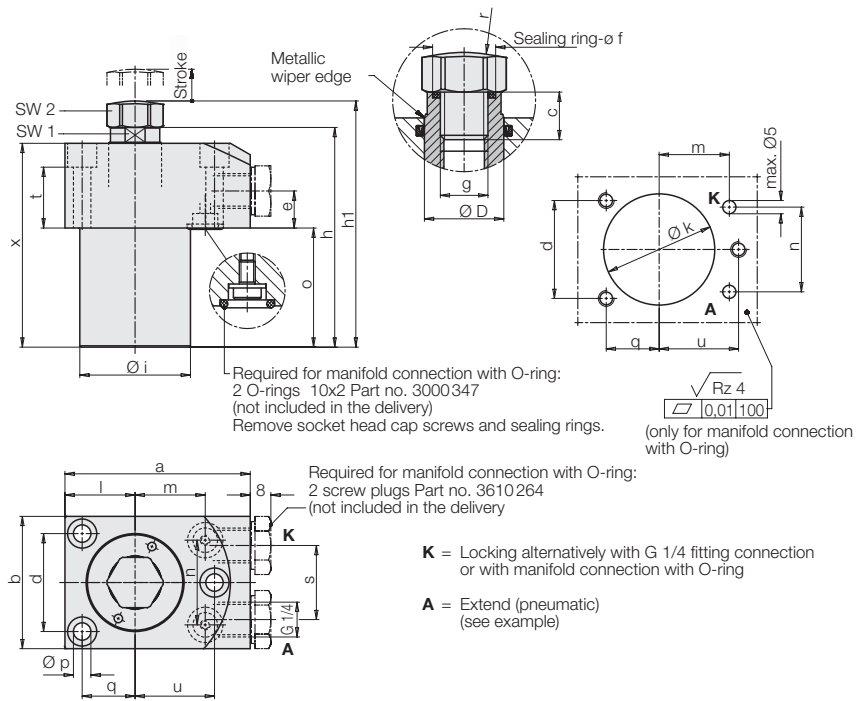

Support plunger Ø D	[mm]	20	32	50
Stroke	[mm]	12	16	20
Load force at 200/500 bar	[kN]	5,6/16,8	14/42	34/102
Spring force min./max.	[N]	15/25	30/60	50/100
Plunger contact force at 1 bar air pressure (deduct spring force if necessary)	[N]	31	80	196
Elastic deformation at 500 bar	[µm/kN]	4,5	2,8	1,8
a	[mm]	70	85	125
b	[mm]	50	63	95
c	[mm]	12	12	20
d	[mm]	37	48	72
e	[mm]	14	18	15
Ø f	[mm]	15,9	15,9	19,6
g	[mm]	M 12	M 12	M 16
h	[mm]	83	103	154
h1	[mm]	93	113	164
Ø i ±0,1	[mm]	44,8	59,8	89,8
Ø k + 1	[mm]	45	60	90
l	[mm]	26,5	34,5	55
m	[mm]	26,5	31	45
n	[mm]	32	46	75
o	[mm]	45	59	106
Ø p	[mm]	6,6	8,5	14
q	[mm]	20	27	42
r	[mm]	45	45	60
s	[mm]	28	41	70
t	[mm]	23	29	26
u	[mm]	30	38	55
x	[mm]	77	99	146
SW 1	[mm]	17	27	41
SW 2	[mm]	19	19	24
Part no.		1953321	1955321	1957321
Spare O-ring 10x2 mm		3000347	3000347	3000347
Screw plug G 1/4		3610264	3610264	3610264
Spare sealing ring for contact bolt		3001731	3001731	3002018

Type of function: Hydraulic pressure and spring advanced extending hydraulically, contact by spring force

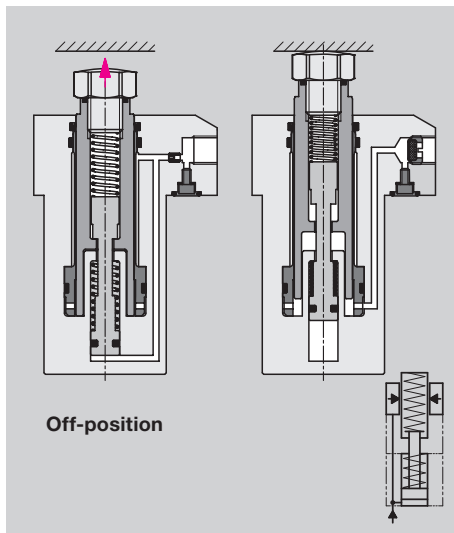

The support plunger is extended by a hydraulically pressurised small piston and contacts the workpiece with spring force.

The support plunger will be locked by the increasing hydraulic pressure and can compensate forces in axis direction.

For unclamping hydraulic pressure will be released. The small piston retracts by spring force to its off-position and also retracts the support plunger.

Venting port

1. Dry machining

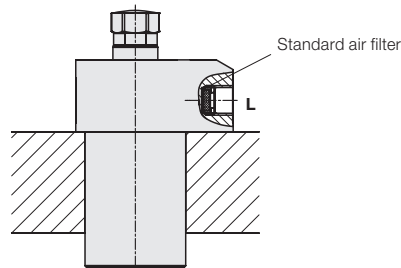

2. Wet machining

Pipe thread

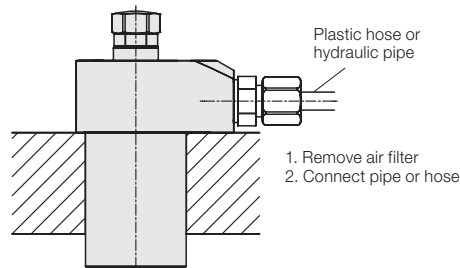

Manifold-mounting connection

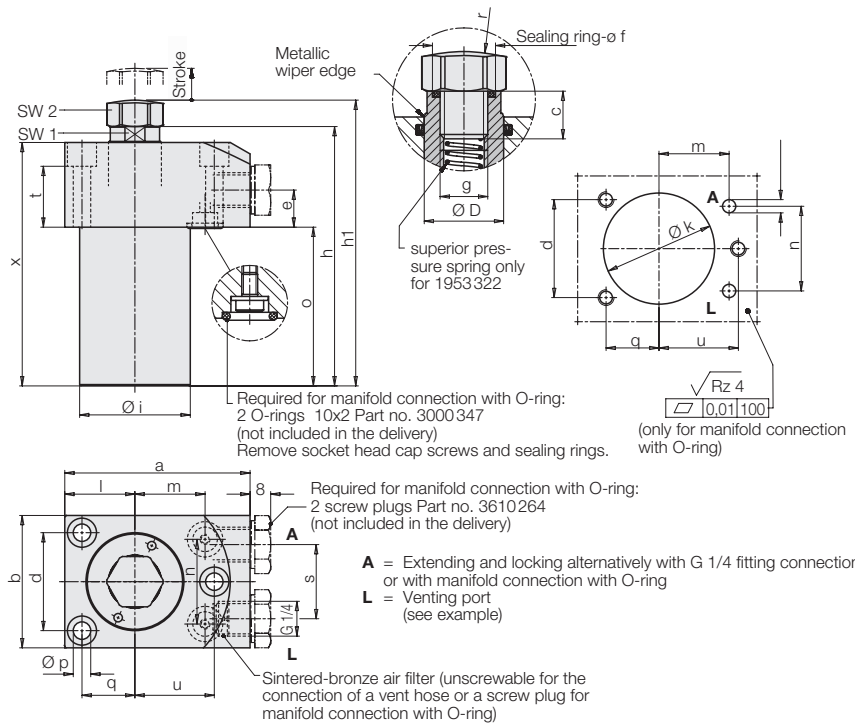
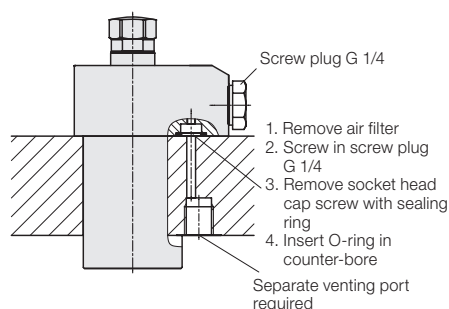

Support plunger Ø D	[mm]	20	32	50
Stroke	[mm]	12	16	20
Load force at 200/500 bar	[kN]	5,6/16,8	14/42	34/102
Plunger contact force min./max.	[N]	15/25	30/60	50/100
Admissible oil flow rate	[cm ³ /sec]	25	35	100
Required oil per stroke	[cm ³]	1,0	3,3	9,8
Elastic deformation at 500 bar*	[mm/kN]	4,5	2,8	1,8
a	[mm]	70	85	125
b	[mm]	50	63	95
c	[mm]	12	12	20
d	[mm]	37	48	72
e	[mm]	14	18	15
Ø f	[mm]	15,9	15,9	19,6
g	[mm]	M12	M12	M16
h	[mm]	98	120	172
h1	[mm]	108	130	182
Ø i ±0,1	[mm]	44,8	59,8	89,8
Ø k +1	[mm]	45	60	90
l	[mm]	26,5	34,5	55
m	[mm]	26,5	31	45
n	[mm]	32	46	75
o	[mm]	60	76	124
Ø p	[mm]	6,6	8,5	14
q	[mm]	20	27	42
r	[mm]	45	45	60
s	[mm]	28	41	70
t	[mm]	23	29	26
u	[mm]	30	38	55
x	[mm]	92	116	164
SW 1	[mm]	17	27	41
SW 2	[mm]	19	19	24
Part no.		1953322	1955322	1957322
Spare O-ring 10x2 mm		3000347	3000347	3000347
Screw plug G 1/4		3610264	3610264	3610264
Spare sealing ring for contact bolt		3001731	3001731	3002018

Recommendation

Positive air pressure protection can be connected to the venting port. The pressure of the positive air pressure protection increases the contact force of the support plunger. For unclamping the positive air pressure protection must be switched off.

Dimensioning of the load force of work supports

The admissible load force of work supports has always to be dimensioned so that the clamping force of the used clamping elements and the static and dynamic machining forces can be safely compensated.

$$\begin{aligned} & \text{Admissible load force} \\ & - \text{Clamping force} \\ & - \text{Safety (reserve)} \\ \hline & = \text{Possible machining force} \end{aligned}$$

If the total of all occurring forces exceeds the admissible load force, the support plunger of the work support will be pushed back and the work support will be damaged.

Ratio of load force to clamping force

On principle the load force of the work supports should be at least twice the clamping force of the clamping elements.

Load force $\geq 2 \times$ clamping force

Clamping onto the work support

Control of clamping sequence

The sequence – supporting and clamping – has to be controlled as a function of the pressure, e.g. by a sequence valve.

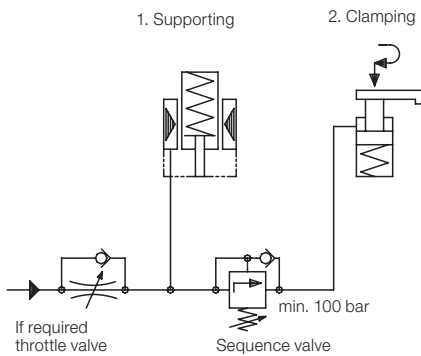

The sequence valve has to be adjusted to an opening pressure above the intersection of the two straight lines in the diagram.

If due to a too high flow rate a throttle valve is required, installation should be made as shown in the hydraulic circuit diagram.

Combinations work supports with swing clamps of the same size

To get a load force twice the clamping force, for all 3 sizes of work supports an operating pressure of at least 200 bar is required.

The vertical distance of the two straight lines in the area of the colorised surface indicates the resulting maximally possible machining force including reserve.

Example

The swing clamp 1895 103 (data sheet B 1.880) clamps a workpiece onto the work support 1955 322.

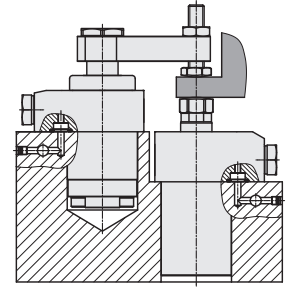

Size 1953

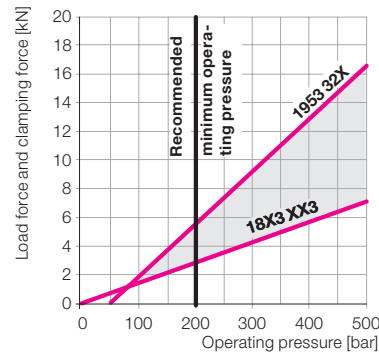

Size 1955

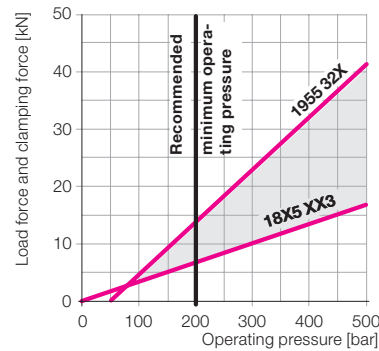

Size 1957

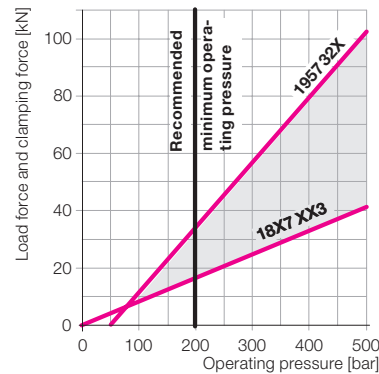

Important note

The admissible load forces as per the diagram are static. The machining forces can also generate vibrations which exceed by far the mean value. For this reason a corresponding safety factor has to be taken into account.

For size 1955 the following can be taken from the diagram:

Minimum operating pressure:	200 bar
Load force at 200 bar:	14 kN
Clamping force at 200 bar:	7 kN

Possible machining force at 200 bar:

Admissible load force:	14 kN
- Clamping force:	- 7 kN
<hr/>	
= Possible machining force:	7 kN
(including reserve)	